



# **Rainbow2 IP Phone User Manual**

Version: 1.2

2014-06-23

# Content

<b>CONTACT ATCOM .....</b>	<b>4</b>
<b>OVERVIEW OF ATCOM .....</b>	<b>4</b>
<b>1. OVERVIEW OF RAINBOW2.....</b>	<b>5</b>
1.1 INTERFACES .....	6
1.2 HARDWARE .....	6
1.3 SOFTWARE .....	6
1.4 NETWORK .....	6
1.5 MANAGEMENT AND MAINTENANCE.....	7
1.6 PROTOCOL .....	7
1.7 COMPLIANT AND CERTIFIED STANDARD .....	7
1.8 PACKING LIST .....	7
1.9 INSTALLATION .....	8
<b>2. KEYPAD OF IP PHONE .....</b>	<b>14</b>
2.1 DESCRIBE OF THE BUTTONS AND SCREEN.....	14
2.2 LINE KEYS LED .....	15
2.3 STATUS INDICATOR .....	15
2.4 PROGRAMMABLE KEYS LED.....	16
2.5 LCD SCREEN ICONS .....	16
<b>3. BASIC FUNCTIONS AND OPERATIONS .....</b>	<b>17</b>
3.1 ANSWER THE CALLS.....	17
3.2 MAKE CALL .....	17
3.3 PRE-DIAL .....	18
3.4 MULTIPLE LINE DIAL-UP .....	18
3.5 HANG UP THE PHONE .....	19
3.6 CALL TRANSFER.....	19
3.7 VOICEMAIL.....	19
3.8 MUTE CALLS.....	19
3.9 CALL HOLD.....	20
3.10 3-WAY CONFERENCE CALL.....	20
3.11 CALL HISTORY.....	20
3.12 DEFAULT PASSWORD .....	21
3.13 CHECK THE PHONE'S IP ADDRESS.....	21
3.14 DIAL PLAN .....	21
<b>4. WEB SETTINGS .....</b>	<b>23</b>
4.1 SYSTEM STATUS.....	23
4.2 NETWORK .....	24
4.2.1 Basic .....	24
4.2.2 Advance.....	25
4.3 SIP SETTING.....	26
4.4 ACCOUNT .....	28
4.5 PHONE SETTING .....	31

4.5.1 Preference .....	31
4.5.2 Features .....	33
4.5.3 Voice .....	35
4.5.4 Ring .....	35
4.5.5 Tone .....	36
4.5.6 Line .....	37
4.5.7 Programmable key .....	37
4.5.8 Rainbow E.....	38
4.6 UPDATE.....	39
4.6.1 Manual Update .....	39
4.6.2 Update/Auto Provision .....	39
4.6.3 Reset & Reboot .....	40
4.7 PHONE BOOK .....	40
4.8 CALL LOG.....	40
<b>5. FAQ &amp; TROUBLE SHOOTING .....</b>	<b>42</b>
5.1 How to make a factory reset.....	42
5.2 Upgrade firmware under safe mode.....	42
5.3 How to make direct IP call .....	42
<b>6. TROUBLE SHOOTING .....</b>	<b>43</b>
6.1 The phone can't register successfully .....	43
6.2 The phone can't obtain IP address.....	43
6.3 Only one part can hear the voice during the call .....	43
<b>7. ABBREVIATIONS .....</b>	<b>44</b>

# Contact ATCOM

## Overview of ATCOM

ATCOM is the leading VoIP hardware manufacturer in global market. We have been keeping innovating with customer's needs oriented , working with partners to establish a total solution for SMB VoIP with IP phone , IP PBX and Asterisk cards

With over 10 years' experience of R&D , manufacturing and service in network and VoIP filed ; mission of creating the biggest value for IP terminals , we commit ourselves in supplying the competitive IP phone and other terminals for IP PBX , softswitch , IMS , NGN providers and carriers; supplying the competitive total VoIP solution for SMB market. We keep improving the customer's experience and creating the bigger value with our reliable products. Until now, our VoIP products have been available in 100+ countries and used by millions of end users.

## Contact Sales

Address	Area C, A2F , Block 3 ,Huangguan Technology Park , #21 Tairan 9th Rd, Chegongmiao , Futian District , Shenzhen China
Tel	+ (86) 755-83018618-8806
Fax	+ (86) 755-83018319
E-mail	<a href="mailto:sales@atcomemail.com">sales@atcomemail.com</a>

## Contact Technical Support

Tel	+ (86) 755-83018618-8008
E-mail	<a href="mailto:Support@atcomemail.com">Support@atcomemail.com</a>

**Website Address:** <http://www.atcom.cn/>

**Download Center:** <http://www.atcom.cn/download.html>

# 1. Overview of Rainbow2



Rainbow2



Rainbow2 with Rainbow E

Type	POE	Power adapter	Rainbow E
Rainbow2	Yes	Optional accessory	Optional accessory

## 1.1 Interfaces

- Power input: DC 5V, 1000mA (DC 5V, 2000mA when with Rainbow E) or POE
- LAN: RJ45 port
- PC: RJ45 port
- EXPAN: RJ45 port
- Headset jack 1 : RJ9 port
- Handset jack 1 : RJ9 port

## 1.2 Hardware

- LCD: 224×128 4-gray scale
- FLASH: 16M
- RAM: 32M
- CPU: 262MHz Dual Core
- LED indicator: 1 Status Light , 4 line indicators, 8 BLF indicators, 1 voicemail indicator, 1 headset indicator, 1 mute indicator
- Rainbow E expansion module: 16 programmable keys on each Rainbow E, can connect up to 5 Rainbow E on a Rainbow2.

## 1.3 Software

- Sip 2.0 (RFC3261) and other related SIP RFCs
- 4 SIP lines registration with 8 concurrent calls
- STUN
- Jitter Buffer, VAD,CNG
- G.711A/u, G.722, G.723, G.726-16, G.726-24, G.726-32, G.726-40, G.729, Lin16-16, iLBC
- Echo Cancellation
- SIP Domain name, Authentication
- DTMF(Inband, RFC2833, SIP INFO)
- Call transfer, Call forward, 3-way conference, Call hold, Call back
- DND(Do Not Disturb), Auto answer, Blacklists, Block Call-ID, Block Anonymous call, Dial plan, IP call
- Phone book with 200 records, 200 answered calls, 200 missed calls, 200 dialed calls
- Auto update via HTTP, FTP, TFTP, PNP
- Syslog
- SNTP
- WEB access with different login level
- Multi-language: English, Chinese, Farsi, French, German, Hebrew, Italian, Portuguese, Russian, Spanish, Turkish
- Soft button: soft button \* 4
- BLF
- Redundancy SIP server

## 1.4 Network

- LAN/PC: Support bridge mode

- Support PPPoE(ADSL,cable modem used for Internet connecting)
- Support VLAN(DATA VLAN and VOICE VLAN)
- Support L2TP VPN
- LAN support Primary and Secondary DNS
- LAN support DHCP Client
- Support QoS

## 1.5 Management and Maintenance

- Support safe mode and firmware updating under safe mode
- Support different level user management
- Configuration via web , keyboard
- Support multi-language
- Firmware and configuration file auto provision
- Support system log and call log

## 1.6 Protocol

- IEEE 802.3 /802.3 u 10 Base T / 100Base TX
- PPPoE: PPP over Ethernet
- DHCP: Dynamic Host Configuration Protocol
- SIP RFC3261, RFC3262, RFC3263, RFC3264, RFC3265, RFC2543, RFC3489, RFC3842, RFC3515, RFC2976, RFC3428, RFC2327, RFC2782, RFC1889
- TCP/IP: Transfer Control Protocol/Internet Protocol
- RTP: Real-time Transport Protocol
- RTCP:RTP Control Protocol
- DNS: Domain Name Server
- TFTP: Trivial File Transfer Protocol
- HTTP:Hypertext Transfer Protocol
- FTP:File Transfer Protocol

## 1.7 Compliant and Certified Standard

- CE: AGC01180140201E2, AGC01180140202E2
- Comply with ROHS in EU
- Comply with ROHS in China



- Operation temperature: lower than 60° C
- Storage temperature: lower than 60° C
- Humidity: 10 to 90% no dew

## 1.8 Packing List

Model	Phone	Handset	Handset line	Stand bracket	Ethern et Cable	User Manual CD
Rainbow2	1	1	1	1	1pcs	1

Note: Power adapter (Input: AC 100~240V, 50/60Hz; Output: 5V,1000mA;)

## 1.9 Installation

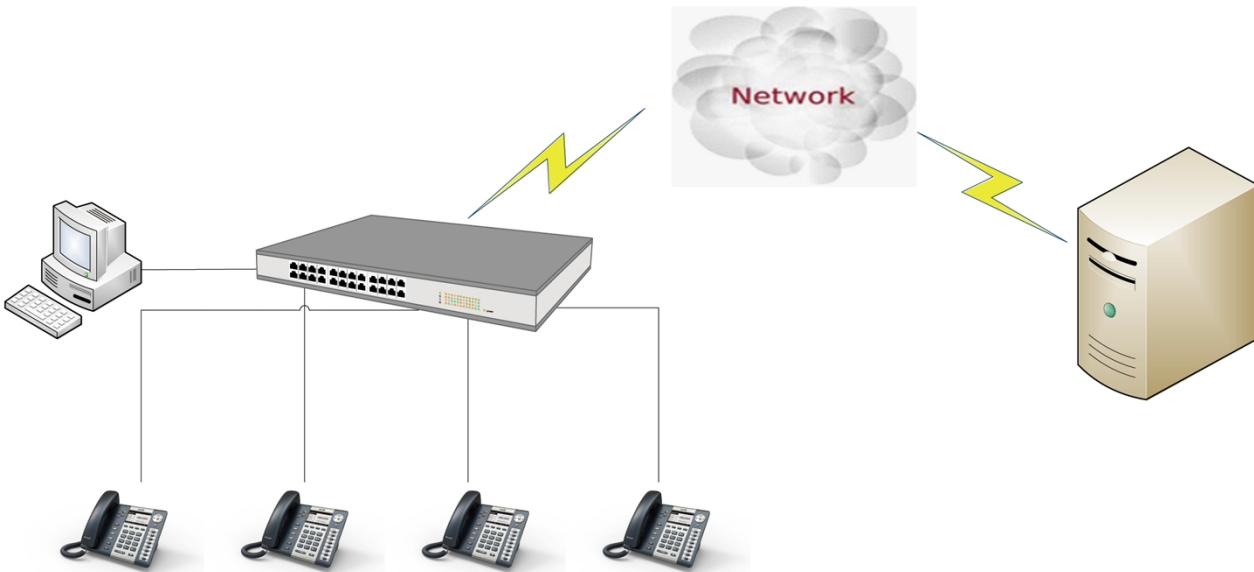

Connect LAN port to PC with Ethernet cable, or connect Rainbow2 to a switch/router which is in the same network as your PC. It uses DHCP mode by default, and you can

review its current IP address by pressing  key on idle state. To access the web interface, you can input the IP address in IE browser. E.G. The IP address of your Rainbow2 is 192.168.1.100, you can input 192.168.1.100 and press enter key on your browser to access its webpage. There are two login level:

User

Admin

The screenshot shows the atcom web interface. The top navigation bar includes 'System Status', 'Network', 'Account', 'Phone Settings', 'Update', 'Phone', and 'Call'. The 'admin' button in the top right corner is circled in red. The main content area displays 'System Status' and 'Product Information' with the following details:

Product Name :	Rainbow2	Protocol :	SIP
Software Version :	1.5.0	Hardware Version :	
Mac Address :	00:09:45:60:58:00	Serial Number :	

No password is set for those two accounts with factory settings. You can click admin button on the right corner of the webpage to switch from the user to admin mode. To set the password for user and admin login you can firstly login as admin and enter the Network--->Advance page as following.



atcom System Status Network SIP Settings Account Phone Settings Update Phone Call

Basic  
Advance

### Web Server

Enable Web Server : Yes

Admin Password :  User Password :

HTTP Port : 80

### VPN

VPN Enable : No VPN Type : L2TP Tunnel

Server Address :

User Name :  Password :

### Stand bracket installation instruction

A. Put the bottom side of the IP phone upside and press one-side joints of stand bracket into the slot, please refer the picture as below:

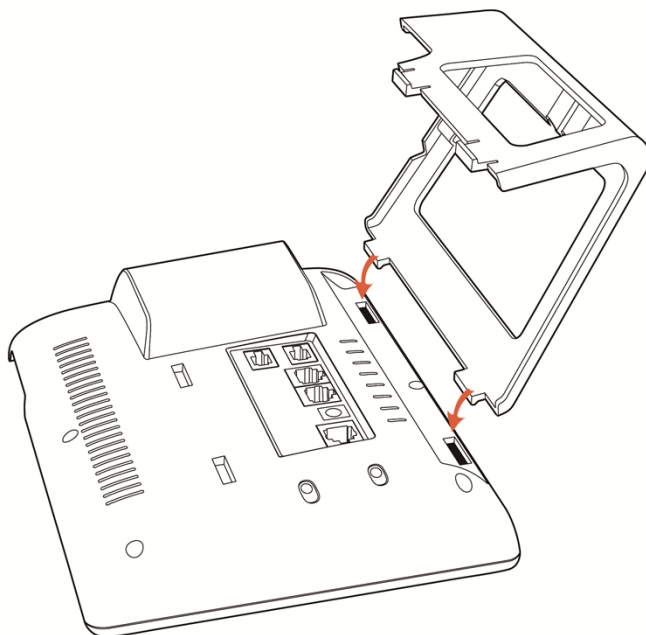

B. Press the other side joints into the slot according to the direction of the arrow:

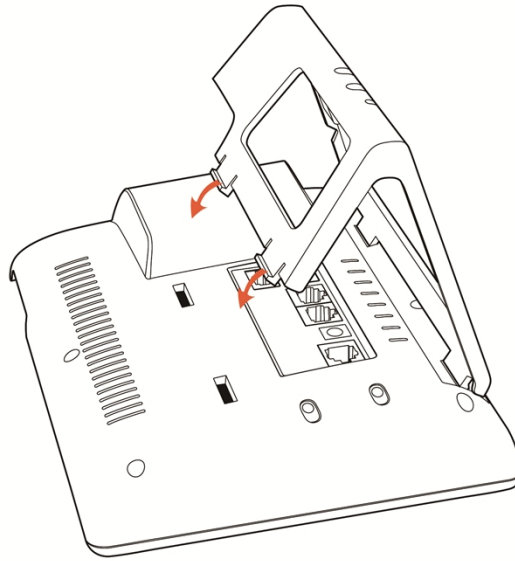

C. It is the right picture after fixing the stand bracket below:

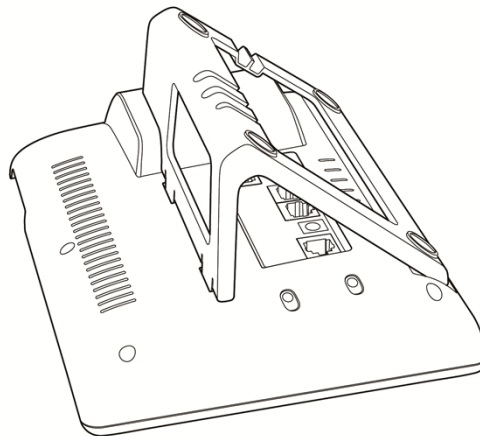

D. Disassemble the stand bracket:

Push the spring joint of stand and pull the stand according to the direction of the arrow. When the joints are pulled out of the slot, you can take off the stand bracket

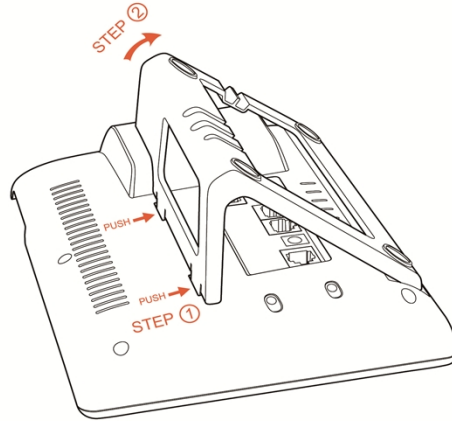

### Wiring instruction

Plug in the power adapter, cable and handset or headset to the corresponding ports as below picture and press them to the slots on the stand bracket.

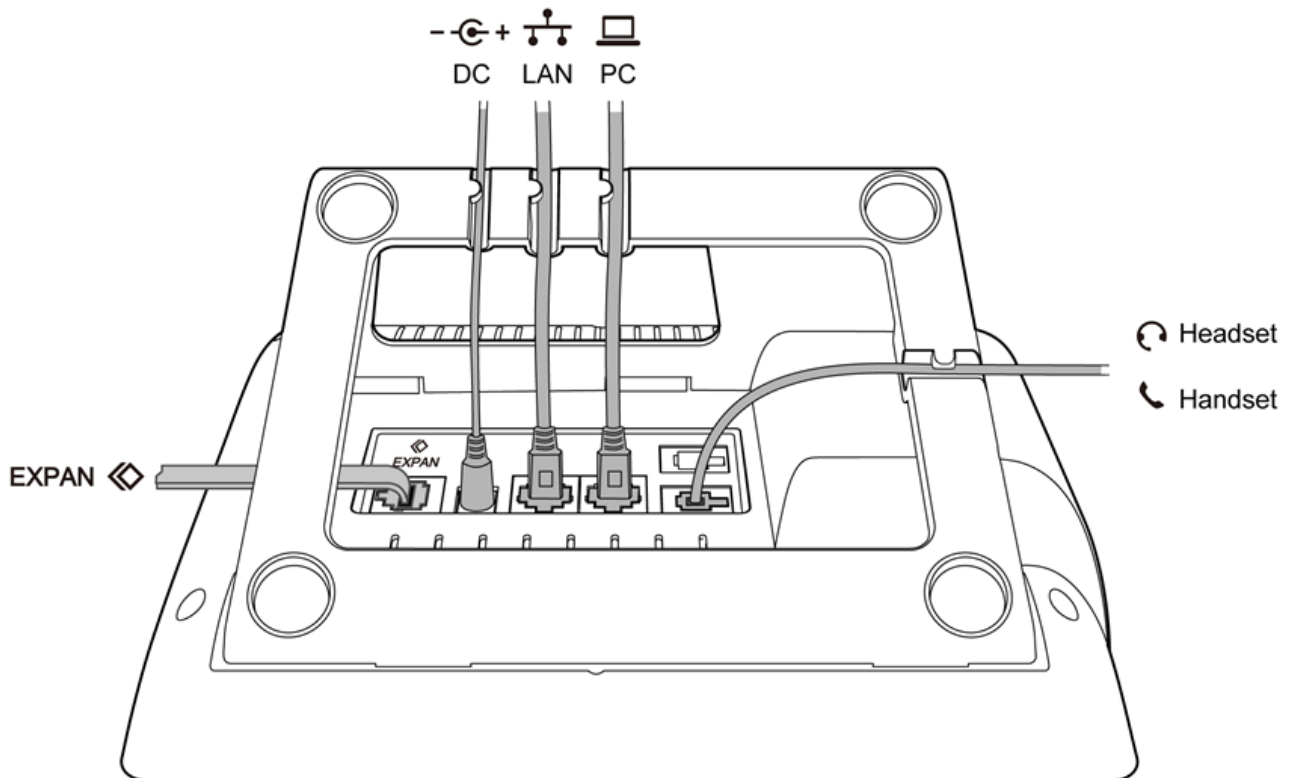

### Programmable keys' paster using instruction

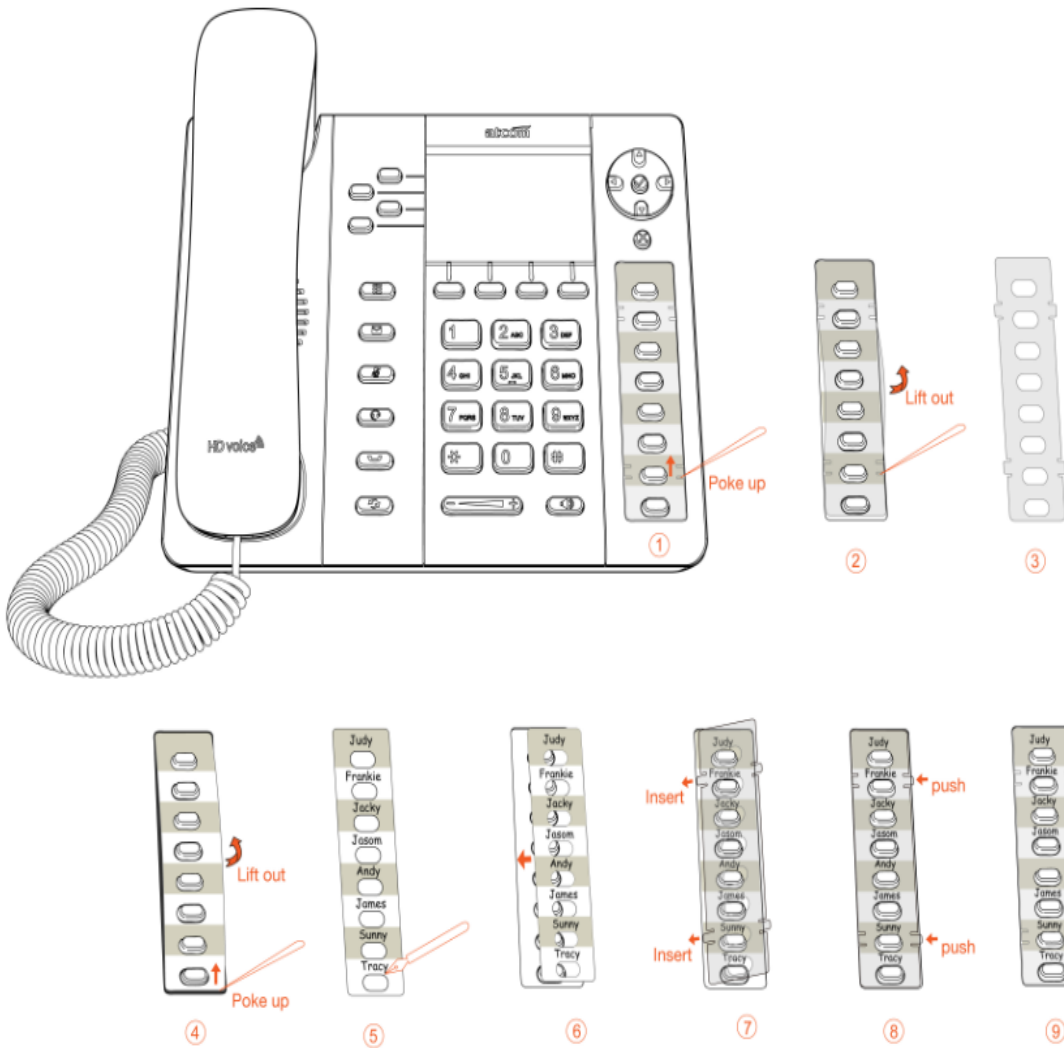

Step1. Use needle or some other tools to insert into the hole of the plastic sheet, hog the plastic sheet.

Step2. Lift out the plastic sheet

Step3. Take off the plastic sheet

Step4. Use needle or some other tools to insert into the edge of the paster, hog and lift out the paster

Step5. Write down the identification of each programmable key on the paster after taking off the paster

Step6. Put back the paster

Step7. Insert the plastic sheet into the slot

Step8. Push the other side of the plastic sheet into the other slot

### Rainbow E's paster using instruction

Steps to use Rainbow E's paster are the same as programmable keys' as below:

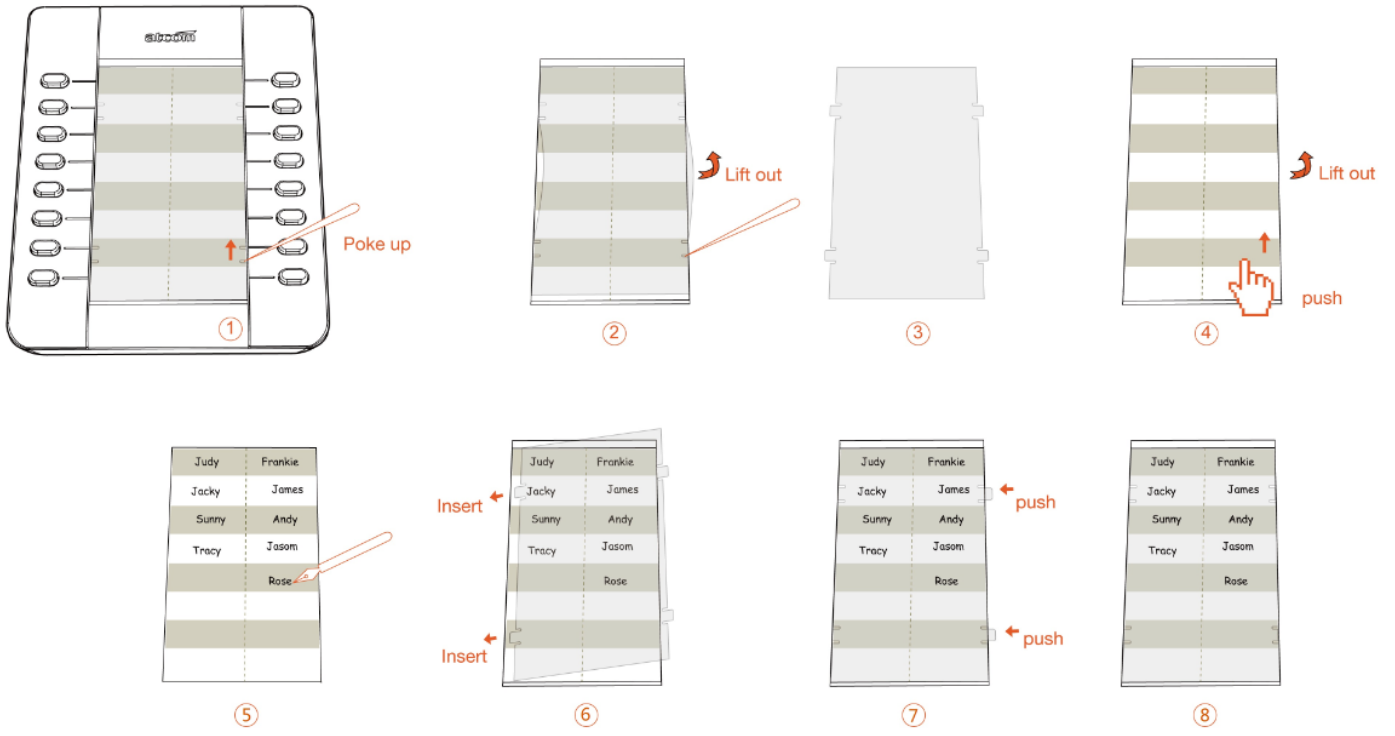



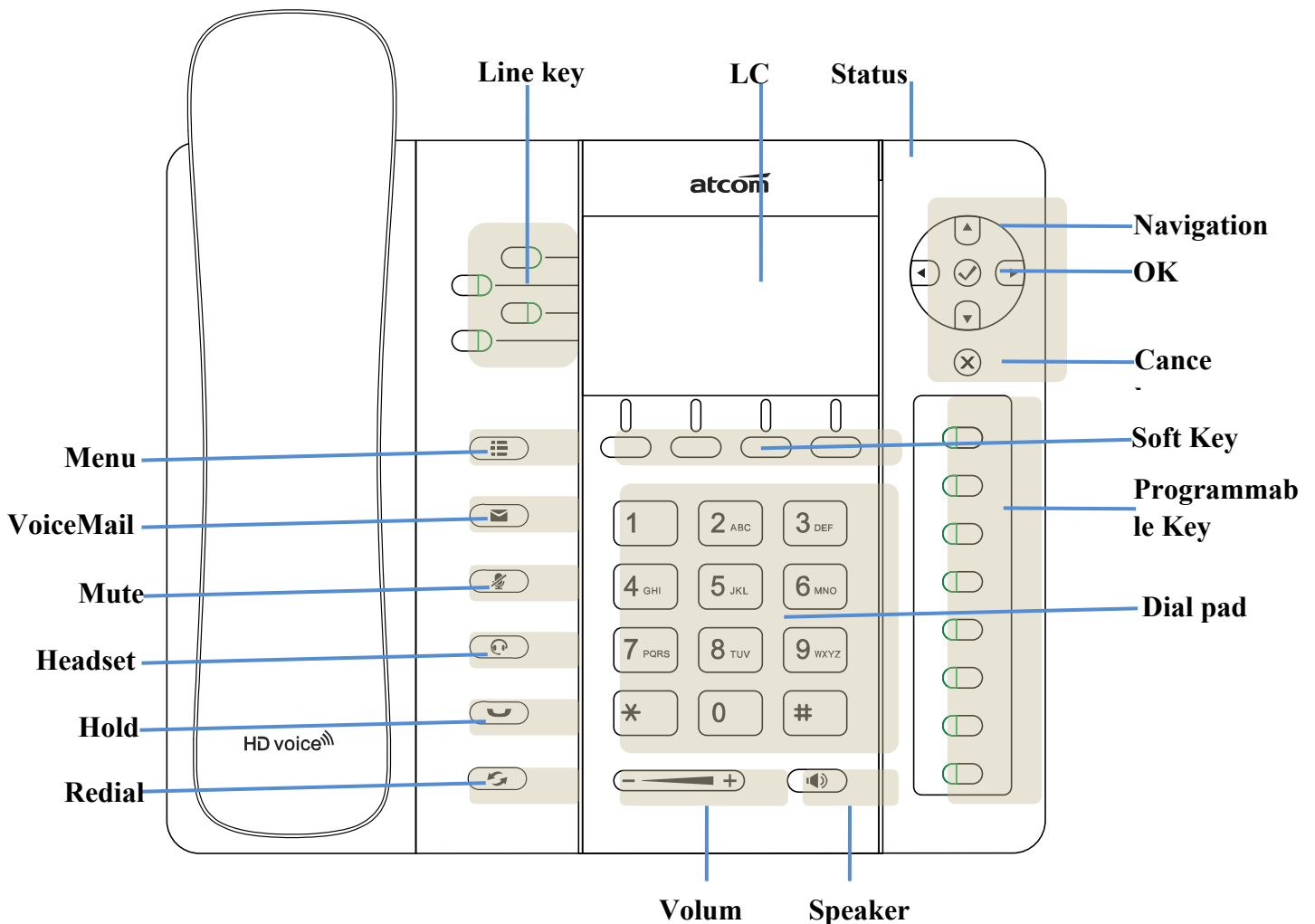









## 2. Keypad of IP Phone



### 2.1 Describe of the buttons and Screen

Soft Keys	Press to select a function which displayed at the softkey zone of screen Display all optional functions at the last line of LCD screen.
Status Indicator	Indicates the phone's status.
LCD Screen	All information such as date, time, phone number, incoming caller's ID(if available),line/call status, extension numbers and the soft key features are displayed on it.
Line Key	Show extension status and choose corresponding line. Long hold the line key will enter the editor interface.
Dial pad	Entering numbers or characters.
Programmable Keys	All the programmable keys can be defined as BLF key, Redial key etc. Long hold the programmable key will enter the editor interface if the programmable key has been already defined as the

	BLF/SpeedDial/DTMF key. Short hold the programmable key will enter the editor interface immediately if the programmable has not been defined.
Navigation keys	Allow users to navigate (left, right, up, down). Press  can enter "Directory". Press  can enter "History".
	Confirm users' operation and show status when Rainbow2 is idle.
	Cancel users' operation.
	Enter menu settings.
	Adjust the volume (speaker/handset/headset/ring). Volume level will be displayed on LCD when pressing volume key.
	Pick up and hung up under the speaker mode.
	Mute the mic in a conversation by pressing the Mute button; this prevents the person on the active call from hearing what you or someone else in the room is saying. If the call is muted, the mute LED is lighted in red. To un-mute, press the Mute button again.
	Pick up and hung up under headset mode. The LED button will be lighted when talking in headset mode.
	Check the Voicemail status. The LED button will be lighted when there is a new message. Long hold will enter the editor interface to configure the voicemail number.
	Hold the current call.
	Redial the last dialed number.

## 2.2

## Line

### keys LED

LED Status	Description
Off	The line is idle or disabled for register
Blink in green at 120ms off, 120ms on	The line has incoming call
Green	The line is talking
Blink in red at 600ms off, 600ms on	The line is held

Table1 Line keys LED Status and Description

### 2.3 Status Indicator

LED Status	Description
On	Rainbow2 is being started

Off	Rainbow2 is standby
Blink in red at 120ms on, 120ms off	There is incoming call

Table2 Status Indicator LED Status and Description

## 2.4 Programmable keys LED

LED Status	Description
Off	The monitored account is unregistered
Green	The monitored account is idle
Red	The monitored account is talking
Fast blink in red	The monitored account is ringing

Table3 Programmable keys LED Status and Description

When powering on, all LEDs will be lighted once.

## 2.5 LCD screen icons















Icon	Description
	The extension is registered
	The extension is unregistered
	There is a new voice mail
	Rainbow2 is dialing
	Rainbow2 is talking
	Rainbow2 is calling
	There is an incoming call
	The call is held
	Rainbow2 is in speaker mode
	Rainbow2 is in handset mode
	Rainbow2 is in headset mode
	Rainbow2 is in conference
	The line key is used as the BLF key and the BLF monitored number is registered
	The line key is used as the BLF key and the BLF monitored number is unregistered
	The line key is used as SpeedDial key

Table4 LED Screen Icons Description





## 3. Basic functions and operations

### 3.1 Answer the calls



When there is an incoming call, phone will remind user with ringing. There are 3 ways to answer the call:

#### A. Answer by handset

Pick up the handset and talk with the caller. If you want to hang up, just put back the handset. When you are talking with the handset and want to switch to speaker or

headset mode, please press  key or  key, then put down the handset.



#### B. Answer by speaker

Press  key and talk with callers by built-in Micro-phone and Speaker. If you want to hang up, please press  key again. Switch calling or talking into

handset mode by lifting the handset under speaker mode. Press  key will switch calling or talking into headset mode.

#### C. Answer by headset

Keep your microphone connected with the RJ9 headset jack, when there is an

incoming call, press  and talk with the caller. If you want to hang up, please press  again. Pressing  can change calling or talking into speaker mode, and lifting the handset switches to handset mode.

### 3.2 Make Call

#### A. Use the handset

Pickup the handset, the LCD will show the current lines (user is able to switch from line1 to line4 by pressing the line key beside the LCD). Press soft key "Send" to dial the number. When you hear the tones of "du~~du~~" and the phone number your dialed is being displayed on the LCD, the phone at the side of being called should be ringing. If the called party answers this calling, the call is established and the calling timer is started immediately.

#### B. Use the speaker



Press  key, the LCD will show the current lines (user is able to switch from line1 to line4 by pressing the line key beside the LCD). Input the phone number and press soft key "Send" to dial the number. When caller hear the tones of "du~~du~~" and the phone number your dialed is being displayed on the LCD, the phone at the

side of being called should be ringing. If the called party answers this calling, the call is established and the calling timer is started immediately.



### C. Use the headset

Press  Key, the LCD will show the current lines (user is able to switch from line1 to line4 by pressing the line key beside the LCD). Input the phone number and press soft key "Send" to dial the number. When caller hear the tones of "du~~du~~" and the phone number your dialed is being displayed on the LCD, the phone at the side of being called should be ringing. If the called party answers this calling, the call is established and the calling timer is started immediately.

### D. Dial from phone book

1. Press  key and input the keypad password 123 to enter the menu and choose "Directory" option. Press "Select" soft key and then find the contact person by navigation keys. When the certain contact person is highlighted, press "Dial" or just pick up the handset to call this number.
2. Pick up the handset, press "Directory" soft key, then select the contact person and press "Dial" soft key.
3. Pick up the handset, press  and enter "Directory", then select the contact person and press "Dial" soft key.

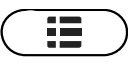
### E. Dial from call history

1. Press  key and input the keypad password 123 to enter the menu and choose "History" option, then enter sub-directory "Dialed Calls", "Received Calls" or "Missed Calls" to select one of call history entry, and press "Dial" soft key or pickup the handset to call this number.
2. Pickup the handset, press "History" soft key, then select one of call history entry, and press "Dial" soft key to call this number.
3. Pickup the handset, press  and enter "Call History", then select one of call history entry, and press "Dial" soft key to call this number.

## 3.3 Pre-dial

It's a method to dial a phone number immediacy at standby mode..

The method is as below:

- A. Dial-up the phone number at standby mode
- B. Press soft key "Dial" to send out the number

## 3.4 Multiple line dial-up

Rainbow2 supports 4 SIP lines. That means user can register on 4 different sip accounts simultaneity. User is able to choose line1, line2, line 3 or line 4 by pressing corresponding line key. Line1 is the priority line.

Rainbow2 maximum supports 8 concurrent calls. When there is an incoming call to another line, LCD will show the incoming telephone number and line LED will be blinking in green. User is able to press the corresponding line key or press soft key "Hold" the current line on which you're talking then press "Answer" to receive the incoming call from another line.

### 3.5 Hang up the phone

#### 1. Handset hang up

Put back the handset at handset mode, the current calling will be hung up.

#### 2. Speaker hang up

Press  key at speaker model, the current calling will be hung up.

#### 3. Headset Hang up

Press  key at headset model, the current calling will be hung up.

#### 4. Hang up one line call

Press the hook to hang up the current calling when 2 calls happened simultaneously.

### 3.6 Call Transfer

#### 1. Attended call transfer

The attended transfer allows user to call a third-party before transferring the calling.

While calling, press the "Transfer" soft key to hold the current call and phone the third party. Then dial the target number you want to transfer to on the activated line and press "Send" soft key to call that number. After the target party answers the call, press "Transfer" soft key again to complete the transfer.

#### 2. Blind call transfer



The blind transfer allows user to transfer a call without speaking to the third party. On the user side, the call will be ended as soon as the target phone number is dialed. Operating steps: Press "More" soft key to get more option, then press "Bxfer" soft key, input the transfer target number and press "Send" soft key.

### 3.7 Voicemail



Rainbow2 has a  key for entering voicemail box and indicating new voicemail.

Press  key to enter the menu to configure voicemail number if you have never configured it previously. Otherwise, the voicemail number will be called after pressing it. If you want to modify it after configured it, please go to the Account webpage to modify voicemail number.

### 3.8 Mute calls

The input audio will be not transmitted to peer phone after pressing  key, and the phone will be muted even switched among different modes of speaker, handset and headset. To un-mute, just press  key again.

### 3.9 Call Hold

The current calling will be hold by pressing soft key "Hold" or . And the held call will be resumed after pressing soft key "Resume" or  or the corresponding line key. Even on 3-way conference calling, the conference will be held after pressing "Hold" key, and be resumed to 3-way conference after pressing "Hold" Key again. Remember the conversation is still on hold without being ended even if hung up under the status of hold.

### 3.10 3-Way Conference Call

To initiate a conference call:

Press "More" soft key on calling to get more options, then press "Conf" soft key to start a conference call. Enter the phone number of the third party and press "Send" soft key to send it out.





1. After the third party answers the call, pressing "Conf" key again to establish the 3-way conference.
2. 3-way conference initiator can press "Exit" soft key to quit from the conference and leave the other two parties still in the conversation.
3. If the initiator hangs up the call or press the "End Conf" soft key, the conference will be ended and the calling between the other two parties will be hung up.



### 3.11 Call History

Rainbow2 supports 200 missed calls, 200 incoming calls and 200 dialed calls. When the storage is full, the old record will be erased by the new one.

Press "History" soft key or  key when Rainbow2 is standby, all the incoming(->), outgoing(<-) and missed calls(!) will be listed. There is another way to check them:



A. Missed call



1. Press  key.
2. Press  key and  key to select "Call History" then press "Select" soft key.
3. Press  key and  key to select "Missed Calls" then press "Select" soft key.



4. Press  key and  key to browse the missed call record. If there is no record, the LCD display will be indicated "List is Empty".

#### B. Answered call

1. Press  key .

2. Press  key and  key to choose "Call History" and then press "Select" soft key.

3. Press  key and  key to choose "Answered Calls" and then press "Select" soft key.



4. Press  key and  key to browse the answered call records. If there is no record, the LCD display will be indicated "List is Empty".

#### C. Dialed call

1) Press  key.

2) Press  key and  key to select "Call History" and then press "Select" soft key.

3) Press  key and  key to select "Dialed Calls" and then press "OK" soft key.

4) Press  key and  key to browse the dialed call records. If there is no record, the LCD display will be indicated "List is Empty".

### 3.12 Default Password

Password is needed to access menu and web.

The default password for accessing menu is 123.

There are 2 modes to access web: User mode and Admin mode. All the parameters can be visible at Admin mode while part of them can be visible at User mode.

#### ➤ User Mode

Username: user                      no default Password

#### ➤ Admin Mode:

Username: admin                      no default Password

### 3.13 Check the Phone's IP address

Press  key, then the status of the phone will be displayed on the screen and you will see the current IP address of the phone.

### 3.14 Dial Plan

Dial plan specify the rule to dial number. The Rainbow2 syntax for the dial plan closely resembles the corresponding syntax specified by MGCP and MEGACO.

Dial plan is stipulated by the below configurable parameters:

- Interdigit Long Timer—refer to [Interdigit long timer](#) for more detail description
- Interdigit Short Timer—refer to [Interdigit short timer](#) for more detail description
- Dial Plan

Dial plan contains a series of digit sequences, separated by the `|` character. The collection of sequences is enclosed in parentheses `(` and `)`.

Default: `(*xx.|xxxxxxxxxxxxx.)`

When user dials a series of digits, Rainbow2 will response in below way:

- No candidate sequences matched, the number will be rejected and display "call ended" on the screen. For instance, the default dial plan only supports digits. And `\*` character or letters will be rejected when input them.
- More than one candidate sequences matched, Rainbow2 will wait for more digits input.
- When input timeout occurs, Rainbow2 will dial the input digits.
- When input `#` character, Rainbow2 will dial the input digits.

Digit Sequence Syntax:

`x`: Matches any one numeric digit (`0` ... `9`)

`[]`: Numeric ranges are allowed within `[]`. For example, `[389]` means `3` or `8` or `9`, `[3-6]` means `3` or `4` or `5` or `6`, `[235-8*]` means `2` or `3` or `5` or `6` or `7` or `8` or `\*`.

`.'`: Any element can be repeated zero or more times by appending a `.` Character. For example, `01.` matches `01,011,0111,01111,...,011111111...etc.`

`<>`: subsequence substitution. For example, `<8:1650>xxxxxx` would match `'85551212'` and the first digit `8` will be replaced by `1650` and `'16505551212'` will be dialed.

`,'`: An "outside line" dial tone can be generated within a sequence by appending a `,'` character between digits. Thus, the sequence `"9, 1xxxxxxxxx"` sounds an "outside line" dial tone after the user presses `9`, until the `1` is pressed.

`!`: A sequence can be barred (rejected) by placing a `!` character at the end of the sequence. For example, `"137xxxxxxxx!"` will forbid numbers which have 11 digits and start by 137 to be dialed.

Example:

`(xxxxxx|[*#]xxxx|9,1xxxxxxxxx|00xxx!)` contains 4 subsequences:

1. Allow to dial numbers with 7 digits
2. Allow to dial numbers with 4 digits and start by `\*` or `#`
3. Allow to play an "outside line" dial tone after pressing `9` and dial numbers with 11 digits and start by 1
4. Forbid to dial numbers with 5 digits and start by 00

## 4. Web settings

Enter Rainbow2's IP address in the web browser and press 'Enter' key to access Rainbow2's user webpage.

Click "admin" which is on the right corner to enter administrator webpage.

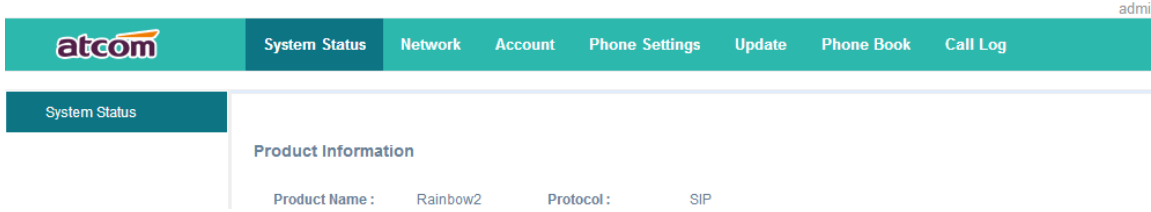

admin

atcom

System Status Network Account Phone Settings Update Phone Book Call Log

System Status

Product Information

Product Name : Rainbow2 Protocol : SIP

### 4.1 System status

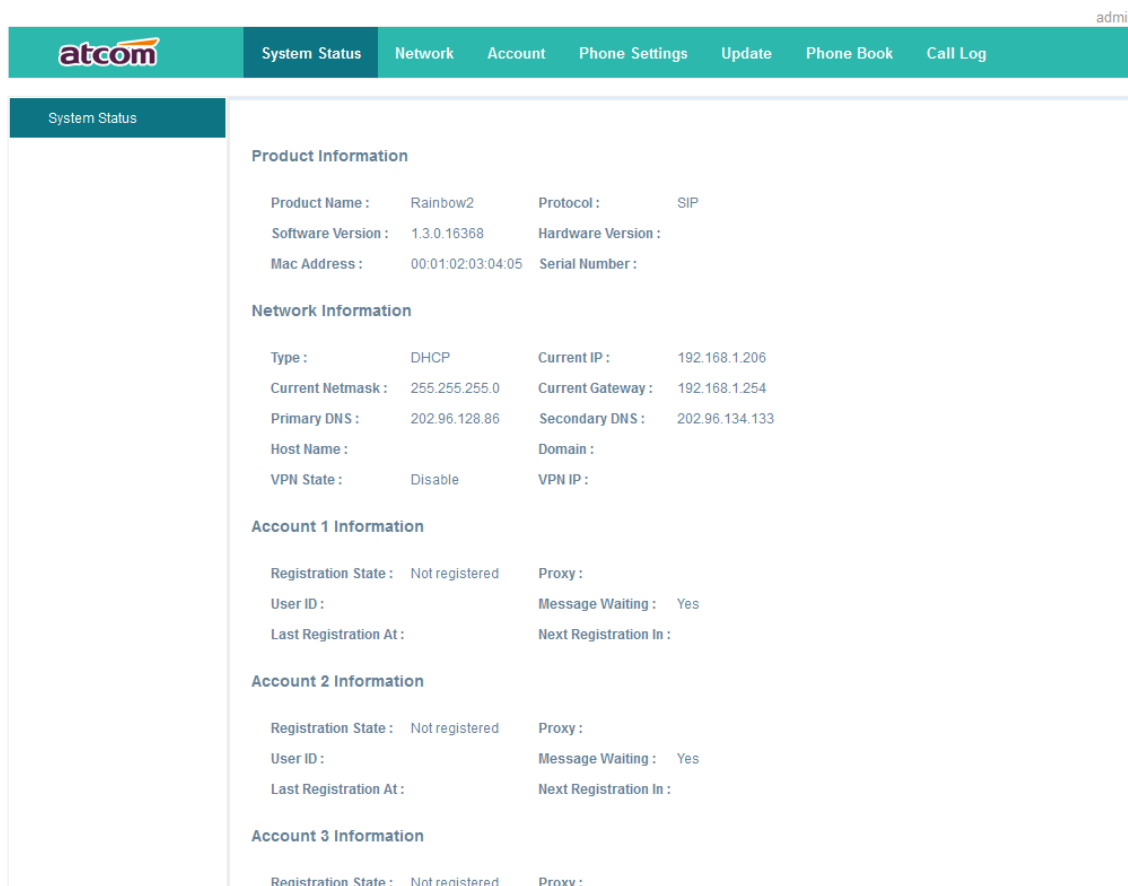

admin

atcom

System Status Network Account Phone Settings Update Phone Book Call Log

System Status

Product Information

Product Name : Rainbow2 Protocol : SIP

Software Version : 1.3.0.16368 Hardware Version :

Mac Address : 00:01:02:03:04:05 Serial Number :

Network Information

Type : DHCP Current IP : 192.168.1.206

Current Netmask : 255.255.255.0 Current Gateway : 192.168.1.254

Primary DNS : 202.96.128.86 Secondary DNS : 202.96.134.133

Host Name : Domain :

VPN State : Disable VPN IP :

Account 1 Information

Registration State : Not registered Proxy :

User ID : Message Waiting : Yes

Last Registration At : Next Registration In :

Account 2 Information

Registration State : Not registered Proxy :

User ID : Message Waiting : Yes

Last Registration At : Next Registration In :

Account 3 Information

Registration State : Not registered Proxy :

This page shows the IP phone's system status.

- Product Information** shows the product name, protocol, software and hardware version, Mac address and serial number.
- Network Information** shows the network connection type, IP, netmask, gateway, DNS, host name, domain and VPN information.
- Account 1/2/3/4 Information** shows registration state, proxy, user ID, message waiting on or off , the last and next registration time.

## 4.2 Network

### 4.2.1 Basic

There are 3 ways to connect to the internet: DHCP, Static and PPPoE, please choose one according to your own situation.

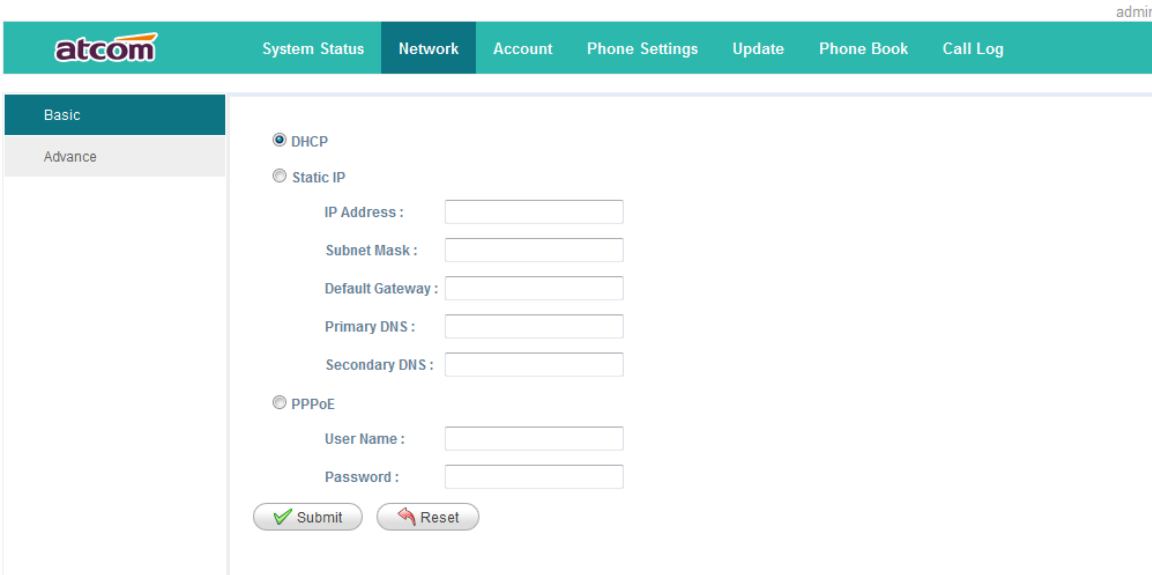

The screenshot shows the 'Network' configuration page in the atcom web interface. The 'Basic' tab is selected, and the 'DHCP' option is chosen. The form includes input fields for IP Address, Subnet Mask, Default Gateway, Primary DNS, and Secondary DNS under the Static IP section, and User Name and Password fields under the PPPoE section. There are 'Submit' and 'Reset' buttons at the bottom.

**Network mode:** DHCP, Static IP and PPPoE

#### 1. DHCP

Auto obtain dynamic IP from DHCP server.

#### 2. Static IP

- a) IP Address: set IP address
- b) Subnet Mask: set netmask
- c) Default Gateway: set gateway
- d) Primary DNS: set primary DNS server
- e) Secondary DNS: set secondary DNS server

#### 3. PPPoE

The LAN port of Rainbow2 connects to the Ethernet port of mode. You should fill in user name and password which were assigned by ISP (internet service provider).

- a) User name: set PPPoE user name
- b) Password: set PPPoE password

Press 'Submit' button after finishing setting and all the settings will be saved and take effect after Rainbow2 reboots.



## 4.2.2 Advance

### ➤ Web Server

#### Web Server

Enable Web Server :	<input type="text" value="Yes"/>		
Admin Password :	<input type="text"/>	User Password :	<input type="text"/>
HTTP Port :	<input type="text" value="80"/>		

- ✓ Enable Web Server: enable or disable web access. If choose "no", you can not access Rainbow2's webpage.
- ✓ Admin password: set admin webpage access password. Enter 'http://ip-address/index.asp' in the web browser to access admin's login webpage after setting the admin password, then input username(admin) and password to access the admin's webpage.
- ✓ User password: set user webpage access password. Enter 'http://ip-address/user.asp' in the web browser to access user's login webpage after setting the user password, then input username(user) and password to access the user's webpage.
- ✓ HTTP port: set port for HTTP(defaults to 80)  
For example, Rainbow2's IP is 192.168.1.223  
HTTP port was set as 100, you have to type "http://192.168.1.223:100" in web browser to enter Rainbow2 webpage.

### ❖ VPN

#### VPN

VPN Enable :	<input type="text" value="No"/>	VPN Type :	<input type="text" value="L2TP Tunnel"/>
Server Address :	<input type="text"/>		
User Name :	<input type="text"/>	Password :	<input type="text"/>

1. VPN Enable: whether to enable VPN
2. VPN Type: only support L2TP VPN
3. Server address: VPN server address
4. Username: VPN account's username
5. Password: VPN account's password

After apply, the phone will reboot. The VPN IP will be shown on the System Status webpage.

### ❖ VLAN

## VLAN

You should receive the tagging values of a virtual LAN from your provider. Wrong settings will require factory reset.

Lan VLAN Enable :	<input type="text" value="No"/>	PC VLAN Enable :	<input type="text" value="No"/>
Lan Identifier(1..4094) :	<input type="text" value="1"/>	PC Identifier(1..4094) :	<input type="text" value="1"/>
Lan Priority :	<input type="text" value="0"/>	PC Priority :	<input type="text" value="0"/>

1. Lan VLAN Enable: Whether to enable VLAN of Lan Port
2. PC VLAN Enable: Whether to enable VLAN of PC Port
3. Lan VLAN Identifier(1..4094) : Assign VLAN id for voice stream, range from 1 to 4094
4. Lan VLAN Priority: the degree is 0-7, 7 is the highest priority.
5. PC VLAN Identifier(1..4094) : Assign VLAN id for data stream, range from 1 to 4094
6. PC VLAN Priority: the degree is 0-7, 7 is the highest priority.

## ➤ Port Link

### Port Link

LAN Port Link :	<input type="text" value="Auto negotiate"/>	PC Port Link :	<input type="text" value="Auto negotiate"/>
-----------------	---------------------------------------------	----------------	---------------------------------------------

## Choose the network type and port link of LAN/PC

1. LAN Port Link: Auto negotiate, full duplex 10Mbps, full duplex 100Mbps, half duplex 10Mbps, half duplex 100Mbps.
2. PC Port Link: Auto negotiate, full duplex 10Mbps, full duplex 100Mbps, half duplex 10Mbps, half duplex 100Mbps.

## ➤ Qos

### Qos

SIP Qos(0..63) :	<input type="text" value="0"/>	Voice Qos(0..63) :	<input type="text" value="0"/>
------------------	--------------------------------	--------------------	--------------------------------

## QoS: Quality of service

1. SIP Qos: Quality of service for SIP (Diffserv)
2. Voice Qos: Quality of service for RTP (Diffserv)

## ➤ Syslog

### Syslog

Enable Syslog :	<input type="text" value="Yes"/>	Log Level :	<input type="text" value="Error"/>
Syslog Server :	<input type="text"/>	Port :	<input type="text" value="514"/>

1. Enable Syslog: whether to enable syslog.
2. Log level: None, Alert, Critical, Error, Warning, Notice, Info, Debug. The debug level is the most detailed.
3. Syslog Server: Syslog Server address.
4. Port: Syslog server port, defaults to 514.

## 4.3 SIP Setting

### ➤ Sip Timer Values

#### Sip Timer Values

Sip T1 :	<input type="text" value="0.5"/>	Sip T2 :	<input type="text" value="4"/>
Sip T4 :	<input type="text" value="5"/>		
Reg Retry Intvl :	<input type="text" value="8"/>	Sub Retry Intvl :	<input type="text" value="10"/>

1. Sip T1: RFC 3261 T1 value (RTT). Range: 0 – 64 sec, defaults to 0.5
2. Sip T2: RFC 3261 T2 value (Maximum retransmit interval for non-INVITE requests and INVITE responses). Range: 0 – 64 sec, defaults to 4
3. Sip T4: RFC 3261 T4 value (Maximum duration a message will remain in the network). Range: 0 – 64 sec, defaults to 5
4. Reg Retry Intvl: Interval to wait before the phone retries registration again after encountering a failure condition during last registration. Range: 0 –65535, defaults to 8
5. Sub Retry Intvl: Interval to wait before the phone retries subscriber again after encountering a failure condition during last subscriber. Range: 0 –65535, defaults to 10

### ➤ RTP Parameters

#### RTP Parameters

RTP Port Min :	<input type="text" value="16384"/>	RTP Port Max :	<input type="text" value="16482"/>
RTP Packet Size(ms) :	<input type="text" value="10"/>		

1. RTP Port Min: Minimum port number for RTP transmission and reception. Range: 1–65535, defaults to 16384
2. RTP Port Max: Maximum port number for RTP transmission and reception. <RTP Port Max> should be at least 2 larger than <RTP port Min>.Range: 1–65535, defaults to 16482
3. RTP Packet Size(ms): Packet size in milliseconds, which can be 10ms, 20ms, 30ms, 40ms, 60ms

### ➤ SDP Payload Types

**SDP Payload Types**

AVT Dynamic Payload :	<input type="text" value="101"/>	G729ab Dynamic Payload :	<input type="text" value="18"/>
G726 Dynamic Payload :	<input type="text" value="108"/>	G726 Mode :	<input type="text" value="32 kBit/s"/>
iLBC Dynamic Payload :	<input type="text" value="98"/>	iLBC Mode :	<input type="text" value="13.3 kBit/s"/>
Lin16 Dynamic Payload :	<input type="text" value="107"/>	Lin16 Codec Name :	<input type="text" value="L16"/>
G711a Codec Name :	<input type="text" value="PCMA"/>	G711u Codec Name :	<input type="text" value="PCMU"/>
AVT Codec Name :	<input type="text" value="telephone-event"/>	G722 Codec Name :	<input type="text" value="G722"/>
G723 Codec Name :	<input type="text" value="G723"/>	G723 Mode :	<input type="text" value="6.3 kBit/s"/>
G726 Codec Name :	<input type="text" value="G726"/>	G729ab Codec Name :	<input type="text" value="G729"/>
iLBC Codec Name :	<input type="text" value="iLBC"/>		

1. AVT Dynamic Payload---RFC2833 payload type. Defaults to 101
2. G729b Dynamic Payload---G729b dynamic payload type. Defaults to 18
3. G726 Dynamic Payload ---G726 dynamic payload type. Defaults to 108
4. G726 Mode ---G726 codec rate, which can be 16 kBit/s,24 kBit/s,32 kBit/s,40 kBit/s. Defaults to 32kBit/s
5. iLBC Dynamic Payload---iLBC dynamic payload type. Defaults to 98
6. iLBC Mode---iLBC codec rate, which can be 13.3kBit/s, 15.2kBit/s. Defaults to 13.3kBit/s
7. Lin16 Dynamic Payload ---Lin16 dynamic payload type, defaults to 102
8. G711a Codec Name---G711a codec name used in SDP, defaults to PCMA
9. G711u Codec Name---G711u codec name used in SDP, defaults to PCMU
10. AVT Codec Name---AVT codec name used in SDP, defaults to telephone-event
11. G722 Codec Name---G722 codec name used in SDP, defaults to G722
12. G723 Codec Name---G723 codec name used in SDP, defaults to G723
13. G723 Mode---G723 codec rate, which can be 6.3kBit/s, 5.3kBit/s, defaults to 5.3kBit/s
14. G726 Codec Name---G726 codec name used in SDP, defaults to G726
15. G729ab Codec Name---G729ab codec name used in SDP, defaults to G729
16. iLBC Codec Name---iLBC codec name used in SDP, defaults to iLBC

**➤ NAT Support Parameters****NAT Support Parameters**

Enable Stun :  Stun Server :

1. Enable Stun: Whether to use stun to discover NAT mapping.
2. Stun Server: Set stun server, which can be IP address or domain name.

## 4.4 Account

Rainbow2 has 4 line keys mapping Account 1, Account 2, Account 3 and Account 4 respectively.

### ➤ SIP

SIP

Enable :	<input type="text" value="Yes"/>	User ID :	<input type="text"/>
Display Name :	<input type="text"/>	Password :	<input type="text"/>
Authenticate ID :	<input type="text"/>	SIP Port :	<input type="text" value="5060"/>
SIP Server :	<input type="text"/>	SIP Redundancy Server :	<input type="text"/>
Use Outbound Proxy :	<input type="text" value="No"/>	Outbound Proxy Server :	<input type="text"/>
Outbound Proxy Server :	<input type="text"/>	Outbound Proxy Port :	<input type="text" value="5060"/>
Register Expires :	<input type="text" value="300"/>	Subscribe Expires :	<input type="text" value="3600"/>
Transport Type :	<input type="text" value="UDP"/>	SIP 100Rel Require :	<input type="text" value="No"/>
Session Timer Enable :	<input type="text" value="No"/>	Early Update Enable :	<input type="text" value="No"/>
Caller ID Display :	<input type="text" value="No"/>	AutoSubscribeMWIEnable :	<input type="text" value="No"/>
Server List :	<input type="text" value="Common"/>	Dns Mode :	<input type="text" value="A Record"/>
BLF List URI :	<input type="text"/>		

1. Enable: whether to enable register.
2. Display Name: This name will display on the LCD screen. It will show the User ID instead if leave Display Name as blank.
3. User ID: Username of sip account.
4. Authenticate ID: normally is the same with User ID, can also leave it as blank.
5. Password: Password of SIP account.
6. SIP Server: SIP server address, support both IP address and domain name.
7. SIP Port: SIP server port , defaults to 5060.
8. SIP Redundancy Server: SIP redundancy server address. It can be configured manually and also can be auto configured as the server address carried in the DNS SRV record if there is a DNS which supports specifying the location of the server or domain for SIP protocol. Only when Rainbow2 fails to register to the SIP Server, it will try to register to the SIP Redundancy Server.
9. Use Outbound Proxy: Whether to use outbound proxy.
10. Outbound Proxy Server: Outbound proxy server address. All signaling request will be send to outbound proxy server firstly.
11. Outbound Proxy Port: Outbound proxy server port.
12. Register Expires: register expire time, defaults to 300 seconds.

13. Subscribe Expires: subscribe expire time, defaults to 3600 seconds.
14. Transport Type: UDP/TCP/TLS. Defaults to UDP.
15. SIP 100Rel Require: whether to enable 100Rel. If enabled, 100rel parameters will be added to the SIP request to support PRACK.
16. Session Timer Enable: whether to enable Session Timer.
17. Early Update Enable: whether to enable Early Update.
18. Caller ID Display: whether to display Caller ID
19. AutoSubscribeMWIEnable: whether to enable SubscribeMWI
20. Server List: choose the server type.
21. DNS Mode: choose the DNS mode
22. BLF List URI: set BLF list URI when Rainbow2 cooperate with Broadworks.

## ➤ Codec Configuration

### Codec Configuration

G711A:	<input type="button" value="Yes"/>	G711U:	<input type="button" value="Yes"/>
AVT:	<input type="button" value="Yes"/>	G722:	<input type="button" value="Yes"/>
G723:	<input type="button" value="Yes"/>	G729ab:	<input type="button" value="Yes"/>
iLBC:	<input type="button" value="Yes"/>	G726-16:	<input type="button" value="Yes"/>
G726-24:	<input type="button" value="Yes"/>	G726-32:	<input type="button" value="Yes"/>
G726-40:	<input type="button" value="Yes"/>	Lin16:	<input type="button" value="Yes"/>
Prefer Codec:	<input type="button" value="G711u"/>	User Prefer Codec Only:	<input type="button" value="No"/>

1. Prefer Codec: Select a preferred codec for all calls. Defaults to G711u. Conversation will be set up by the prefer codec preferentially if the far end also supports this codec.  
However, the actual codec used in a call still depends on the outcome of the codec negotiation protocol.
2. User Prefer Codec Only: Only use the preferred codec for all calls. The call will fail if the far end does not support this codec.

## ➤ DTMF Configuration

### DTMF Configuration

DTMF Tx Method:	<input type="button" value="RFC2833"/>	DTMF Display:	<input type="button" value="Yes"/>
-----------------	----------------------------------------	---------------	------------------------------------

1. DTMF Tx Method: Select the method to transmit DTMF signals to the far end: Inband, RFC2833, SIP INFO. Default to RFC2833.

2. DTMF Display: Whether to enable display DTMF as plaintext. Default to Yes.

## ➤ Call Feature Setting

### Call Feature Settings

Message Waiting :	<input type="text" value="Yes"/>	Voice Mail Number :	<input type="text"/>
Pickup Service Code :	<input type="text" value="*8"/>		
UDP Keep Alive Enable :	<input type="text" value="No"/>	UDP Keep Alive Intvl :	<input type="text" value="15"/>
Default Ring :	<input type="text" value="2"/>		
SRTP :	<input type="text" value="No"/>		

1. Message Waiting: whether to prompt if there is a voicemail.
2. Voice Mail Number: set voicemail number.
3. Pickup Service Code: set Pickup Service Code.
4. UDP Keep Alive Enable: whether to enable UDP keep alive. If enabled, Rainbow2 sends UDP packets periodically to keep the server port alive.
5. UDP Keep Alive Intvl: Set interval to send UDP packets.
6. Default Ring: set default ring tone.
7. SRTP: whether to enable SRTP (Secure Real Time Control Protocol). Only can be used if server supports SRTP.

## ➤ Dial Plan

### Dial Plan

Dial Plan :

Dial Plan: Configure dial rule for SIP account, please refer to [dial plan](#).

## 4.5 Phone Setting

### 4.5.1 Preference

#### Language

Language :

#### Output Volume(1~8)

Handset Volume :

SpeakerPhone Volume :

Headset Volume :

Ring Volume :

#### Input Gain

Handset Gain :

SpeakerPhone Mic Gain :

Headset Gain :

#### LCD

Backlight Level :

Backlight Time(Seconds) :

Contrast :

Keypad Password :

#### ➤ Language

Support customizable multi-language.

#### ➤ Output Volume(1~8)

1. Handset Volume: Specify handset volume grade
2. SpeakerPhone Volume: Specify speaker volume grade
3. Headset Volume: Specify headset volume grade
4. Ring Volume: Specify ring tone volume grade

#### ➤ Input Gain

1. Handset Gain: Specify handset gain, the bigger the gain, the louder the other end heard.
2. SpeakerPhone Mic Volume: Specify speaker gain, the bigger the gain, the louder the other end heard.
3. Headset Volume: Specify headset gain, the bigger the gain, the louder the other end heard.

#### ➤ LCD

1. Backlight Level: select the backlight level
2. Backlight Time(Seconds): select the backlight time
3. Contrast: select the contrast level
4. Keypad Password: set keypad access password

#### ➤ Control Timer Values(Seconds)



**Control Timer Values(Seconds)**

Interdigit Long Timer :	<input type="text" value="20"/>	Interdigit Short Timer :	<input type="text" value="8"/>
Reorder Delay :	<input type="text" value="3"/>	Reorder Time :	<input type="text" value="5"/>

1. Interdigit Long Timer: If the numbers or characters input are not finished and they have not matched the full dial plan, the phone will wait for the long time that has been set and then dial them out automatically. Range: 1 – 64 sec
2. Interdigit Short Timer: If the numbers or characters input are matched the full dial plan, the phone will wait for the short time that has been set and then dial them out automatically. Range: 1 – 64 sec
3. Reorder Delay: Delay after far end hangs up before reorder tone is played. 0 means play reorder tone immediately. Range: 0 – 60 sec
4. Reorder Time: Set the duration of showing Call ended

**➤ Date And Time****Date And Time****⊙ NTP**

NTP Server :	<input type="text" value="pool.ntp.org"/>
Time Zone :	<input type="text" value="(GMT+08:00)Beijing, Chongqing, Hong Kong, Urumqi"/>

**⊙ Manual**

Set Local Date(YYYY/mm/dd) :	<input type="text"/>
Set Local Time(HH:mm:ss) :	<input type="text"/>

**Daylight Saving Time**

Daylight Saving Time :	<input type="text" value="No"/>
Daylight Saving Time Rule :	<input type="text"/>

**NTP: Network time protocol**

1. NTP Server: Set NTP server address, which can be IP address or domain name.
2. Time Zone: Choose your own time zone.
3. Daylight Saving Time: whether to enable Daylight saving time.
4. Daylight Saving Time Rule: This parameter is a rule with three fields, each field is separated by semicolon; as show below:  
Start=<start-time>; end=<end-time>; save=<save-time>

<start-time> and <end-time> specify the start and end date of daylight saving time, month/date/week and <save-time> is the amount of hour/min/sec to add to the current time during daylight saving period. The <save-time> value can be preceded by a negative (-) sign if subtraction is desired instead of addition.



If <weekday > is 0, it means the date to start or end daylight saving is at exactly the given date. In that case, the <day> value must not be negative. If <weekday > is not zero, then the daylight saving starts or ends on the <weekday > on or after the given date if <day> is positive, or on or before the given date if <day> is negative. If

<day> is -1, it means the <weekday> on or before the end-of-the -month (in other words the last occurrence of <weekday> in that month)

Optional values inside [] are assumed to be 0 if they are not specified. Midnight means 0:0:0 of the given date.

E.G. start=4/1/7/8:00:00;end=10/1/7/9:00:00;  
 save=-1 Start time is 1st April, Sunday, 8:00:00 am.  
 End time is 1st October, Sunday, 9:00:00 am.  
 The display time will be one hour early than the standard time.

## Manual

1. Set Local Date(YYYY/mm/dd): manually set local date or click  to choose local date .Format: year/month/day.
2. Set Local Time(HH:mm:ss) : manually set local time or click  to adjust local time. Format: hour/minute/second. e.g. 12:00:00.

## 4.5.2 Features

### ➤ Speed Dial

#### Speed Dial

Speed Dial 2 :	<input type="text"/>	Speed Dial 3 :	<input type="text"/>
Speed Dial 4 :	<input type="text"/>	Speed Dial 5 :	<input type="text"/>
Speed Dial 6 :	<input type="text"/>	Speed Dial 7 :	<input type="text"/>
Speed Dial 8 :	<input type="text"/>	Speed Dial 9 :	<input type="text"/>

Set speed dial for 2-9. For example, set Speed Dial 2: 123456789, then if you press 2, 123456789 will be dialed immediately. 3/4/5.../9 also can be set as speed dial.

### ➤ Call Forward

#### Call Forward

Always Target:	<input type="text"/>	Busy Target:	<input type="text"/>
No Answer :	<input type="text"/>		
After Ring Time(Seconds):	<input type="text" value="5"/>		

1. Always Target: Every incoming call will forward to this target.
2. Busy Target: The incoming call will forward to this target when Rainbow2 is busy.
3. No Answer: The incoming call will forward to this target when there is no answer.
4. After Ring Time (Seconds): After this time, the incoming call will be forwarded to the no answer target. Defaults to 5.  
 The priority of Always Target is highest when Always Target, Busy Target and No Answer Target have been set. This means all the incoming call will be forwarded to the Always Target.

## ➤ Call Settings

### Call Settings

Do Not disturb :	<input type="text" value="No"/>	Call Waiting :	<input type="text" value="Yes"/>
Block Call ID :	<input type="text" value="No"/>	Block Anc Call :	<input type="text" value="No"/>
Auto Answer :	<input type="text" value="No"/>		

### Others

Send Key :

1. Do Not Disturb: Whether to enable Do Not Disturb, when enabled, all the incoming call will be rejected. If Always Target or Busy Target was set at the same time, then incoming call will be forwarded to the targets preferentially.
2. Call Waiting: When enable Call Waiting and Rainbow2 is in conversation, incoming call will not be rejected and ringback tone can be heard by the far end. When disable Call Waiting, there should be only one conversation no matter how many accounts have been registered on Rainbow2.
3. Block Call ID: When enable Block caller ID, Rainbow2 will call others as anonymous.
4. Block Anc Call: When enable block anonymous call, Rainbow2 will reject anonymous caller.
5. Auto Answer: When enable Auto Answer, Rainbow2 will answer the incoming call by speaker automatically.
6. Send key: Define the send key as # or \*, press # or \* after dial number, then number will be sent out immediately.

### 4.5.3 Voice

Preference	
Features	
<b>Voice</b>	
Ring	
Tone	
Line Key	
Programmable Key	
Ext Key	

#### Echo Cancellation

VAD :       CNG :

#### Jitter Buffer

Type :

Min Delay :       Max Delay :

Normal Delay :

### Echo Cancellation

1. VAD: Whether to enable VAD (Voice Active Detection). If enable, RTP packets will not be send when Rainbow2 is mute.

2. CNG: Whether to enable CNG(Comfort Noise Generator). If enable, comfort noise will be send to the far end to let it perceive the activity of the conversation when Rainbow2 is mute.

## Jitter Buffer

Rainbow2 can buffer incoming voice packets to minimize out-of-order packet arrival. This process is known as jitter buffer.

1. Type: Choose type of jitter buffer. When choose Fixed, the size jitter buffer is fixed. When choose Adaptive, the size of jitter buffer is the sum of Min Delay and the size of RTP packets.
2. Min Delay: The minimum delay of the jitter buffer.
3. Max Delay: The maximum delay of the jitter buffer.
4. Normal Delay: It is used for fixed jitter buffer which should be between Min Delay and Max Delay.

### 4.5.4 Ring

Preference	<p>Notes: Ring tone must be wav file, 8k sampling rate ,8 Bit u-law compression. File size should &lt; 200Kbytes</p> <p>Upload Ring Tone <input type="button" value="Choose File"/> No file chosen <input type="button" value="Upload"/></p> <p>Ring Tone Type <input type="button" value="User Define 1"/> <input type="button" value="Delete"/></p>
Features	
Voice	
<b>Ring</b>	
Tone	
Line Key	

Administer can upload 2 user define ring for Rainbow2. The ring file should be wav(8k, 8bit, u-law) and no larger than 200 KBytes.

### 4.5.5 Tone

Preference	<p><b>Tone</b></p> <p>Country Stands : <input type="button" value="Custom"/></p> <p>Dial Tone : <input type="text" value="350@-30,440@-30,60(*0/1+2)"/></p> <p>Outside Dial Tone : <input type="text" value="420@-30,60(*0/1)"/></p> <p>Busy Tone : <input type="text" value="480@-23,620@-23,10(.5/.5/1+2)"/></p> <p>Reorder Tone : <input type="text" value="480@-23,620@-23,10(.25/.25/1+2)"/></p> <p>Off Hook Warning Tone : <input type="text" value="480@-21,620@0,10(.125/.125/1+2)"/></p> <p>Ring Back Tone : <input type="text" value="440@-23,480@-23;*(2/4/1+2)"/></p> <p>MWI Dial Tone : <input type="text" value="350@-30,440@-30,2(.1/.1/1+2);10(*0/1+2)"/></p> <p>Holding Tone : <input type="text" value="350@-30,440@-30,60(*0/1+2)"/></p> <p>Conference Tone : <input type="text" value="350@-23,20(.1/.1/1,.1/9.7/1)"/></p> <p><input type="button" value="Submit"/> <input type="button" value="Reset"/></p>
Features	
Voice	
Ring	
<b>Tone</b>	
Line Key	
Programmable Key	
Ext Key	

Set the ToneScript for each tone.

For example, MWI Dial Tone: 350@-19,440@-19;2(.1/,1/1=2);10(\*0/1+2)  
 Frequency1, Frequency2 ;Cadence Section1;Cadence Section2  
350@-19: Frequency1 is 350HZ at -19dBm

440@-19: Frequency2 is 440HZ at -19dBm

2(.1/,1/1=2): Cadence Section length is 2s, 0.1s on, 0.1s off, with frequencies 1 and 2

10(\*0/1+2): Cadence Section length is 10s, always on(\* means always, 0 means never), with frequencies 1 and 2.

1. Country stands: select a country standard tone as default.
2. Dial Tone: Play when prompting the user to enter a phone number.
3. Outside Dial Tone: An alternative to Dial Tone usually used to prompt the user to enter an external phone number (versus an internal extension). This is triggered by a “,” character encountered in the dial plan.
4. Busy Tone: Play when a 486 RSC is received for an outbound call.
5. Reorder Tone: Play when an outbound call has failed or after the far end hangs up during an established call.
6. Off Hook Warning Tone: Play when user does not place the handset on the cradle properly.
7. Ring Back Tone: Play for an outbound call when the far end is ringing.
8. MWI Dial Tone: Play when there are unheard voicemails.
9. Holding Tone: Indicate to the local user that the far end has placed the call on hold.
10. Conference Tone: Play to all parties when a 3 way conference is in progress.

#### 4.5.6 Line

Preference	Mode	Account	Number
Features			
Voice			
Ring			
Tone			
Line Key			
Programmable Key			

Mode	Account	Number
Line Key 1	Line	Account 1
Line Key 2	Line	Account 2
Line Key 3	Line	Account 3
Line Key 4	Line	Account 4

- ✓ Mode:
  - Line: Set the Line Key as the SIP line
  - BLF: Set the Line Key as the BLF programmable key
  - SpeedDial: Set the Line Key as the SpeedDial key
- ✓ Account:
  - Specify account for each Line Key
- ✓ Number:
  - Set number for the BLF or SpeedDial key.

## 4.5.7 Programmable key

Preference	Mode	Account	Number
Line			
Features			
Voice			
Ring			
Tone			
<b>Programmable Key</b>			
Ext Key			

Key	Mode	Account	Number
Key 1	None	Account 1	
Key 2	None	Account 1	
Key 3	None	Account 1	
Key 4	None	Account 1	
Key 5	None	Account 1	
Key 6	None	Account 1	
Key 7	None	Account 1	
Key 8	None	Account 1	

### ✓ Mode:

- None: Do not use this programmable key
  - SpeedDial: SpeedDial, need to fill a speed dial number.
  - BLF: Busy lamp field, need to fill a BLF number to monitor.  
When the BLF number is ringing, the BLF key will turn to green and blink.  
When the BLF number is during a call, the BLF key will stay for green.  
The BLF key will be off, if the BLF number is idle or not online. And you can press the BLF Key to call the monitored number.
  - DTMF: Send DTMF number
- ✓ Account: which account you want to used.
- ✓ Number: which number to set for SpeedDial, BLF, DTMF.

## 4.5.8 Rainbow E

user

Preference	Mode	Account	Number
Line			
Features			
Voice			
Ring			
Tone			
Programmable Key			
<b>Ext Key</b>			

Attendant Module 1			
Key	Mode	Account	Number
Key 1	None	Account 1	
Key 2	None	Account 1	
Key 3	None	Account 1	
Key 4	None	Account 1	
Key 5	None	Account 1	
Key 6	None	Account 1	
Key 7	None	Account 1	
Key 8	None	Account 1	
Key 9	None	Account 1	
Key 10	None	Account 1	
Key 11	None	Account 1	
Key 12	None	Account 1	
Key 13	None	Account 1	
Key 14	None	Account 1	
Key 15	None	Account 1	
Key 16	None	Account 1	

Rainbow2 can connect 5 Rainbow E at most. There are 16 keys on Rainbow E. After connecting Rainbow E to Rainbow2's EXT port, Rainbow2 will auto detect Rainbow E. Rainbow E can be configured to support two functions: Speed dial and BLF.

- ✓ Event:
  - None: Do not use this BLF key
  - Speed dial: Speed dial, need to fill a speed dial number.
  - BLF: Busy lamp field, need to fill a BLF number to monitor.  
When the BLF number is ringing, the BLF key will turn to green and blink.  
When the BLF number is during a call, the BLF key will stay for green.  
The BLF key will be off, if the BLF number is idle or not online. And you can press the BLF Key to call the monitored number.
- ✓ Account: which account you want to use.
- ✓ Number: number set for Speed dial and BLF.

## 4.6 Update

### 4.6.1 Manual Update

Manual Update		
Auto Provision		
Reset & Reboot		
<b>Bootloader Version:</b>	2.7	
<b>Software Version:</b>	1.5.0.18211	
<b>Hardware Version:</b>		
<b>Boot Loader:</b>	<input type="button" value="Choose File"/> No file chosen	<input type="button" value="Upgrade"/>
<b>Software:</b>	<input type="button" value="Choose File"/> No file chosen	<input type="button" value="Upgrade"/>
<b>Driver:</b>	<input type="button" value="Choose File"/> No file chosen	<input type="button" value="Upgrade"/>
<b>Configuration:</b>	<input type="button" value="Choose File"/> No file chosen	<input type="button" value="Upgrade"/> <input type="button" value="Download"/>
<b>Phone Book:</b>	<input type="button" value="Choose File"/> No file chosen	<input type="button" value="Upgrade"/> <input type="button" value="Download"/>
<b>Attendant Keys:</b>	<input type="button" value="Choose File"/> No file chosen	<input type="button" value="Upgrade"/> <input type="button" value="Download"/>
<b>Audio Quality Control File:</b>	<input type="button" value="Choose File"/> No file chosen	<input type="button" value="Upgrade"/>

1. Boot Loader: Download Boot file from ATCOM's webpage, then select the file from your PC to upgrade.
2. Software: Download software from ATCOM's webpage, then select software from your PC to upgrade.
3. Driver: Download driver from ATCOM's webpage, then select driver from your PC to upgrade.
4. Configuration: Upgrade config.xml file.
5. Phone Book: Upgrade phonebook.xml file
6. Attendant Keys: Upgrade Rainbow E's configuration
7. Audio Quality Control File: Upgrade the Audio quality control file

## 4.6.2 Update/Auto Provision

Manual Update	<b>Configuration Profile</b> Provision Enable : <input type="text" value="No"/> Resync Random Delay : <input type="text" value="0"/> Profile Rule : <input type="text"/> <small>right format,like http://192.168.1.121/config.xml</small>
<b>Auto Provision</b>	
Reset & Reboot	
	<b>Firmware Upgrade</b> Upgrade Enable : <input type="text" value="No"/> Error Retry Delay : <input type="text" value="0"/> Upgrade Rule : <input type="text"/> <small>right format,like http://192.168.1.121/FirmwareName.FW</small>

### Configuration Profile

1. Provision Enable: whether to enable auto provision
2. Resync Random Delay: set a random delay for upgrade configuration files.
3. Profile Rule: support FTP/TFTP/HTTP protocol

### Firmware Upgrade

1. Update Enable: whether to enable firmware update
2. Error Retry Delay: set interval to retry update after encountering failed update
3. Upgrade Rule: the same as Profile Rule, the suffix of the firmware name should be '.fw' or '.FW' and the firmware name should not contain blank character or Chinese characters.

## 4.6.3 Reset & Reboot

Manual Update	<b>Reboot System Now</b> <input type="button" value="Reboot"/> <small>Warning : Reboot system will terminate all active calls!</small>
Auto Provision	
<b>Reset &amp; Reboot</b>	
	<b>Reset to Factory Setting</b> <input type="button" value="Reset"/> <small>Warning : A factory Reset will erase all configuration data on the system! Please do not power off the system. Any power interruption during this time could cause damage to the system!</small>

### 1. Reboot

Reboot will terminate all active calls, and cost a little time to restart.

### 2. Reset

Reset will set Rainbow2 to factory default, please backup the config.xml, phonebook.xml and attendant\_keypad.xml before reset.

## 4.7 Phone Book

<b>Phone Book</b>	<input type="button" value="New Contact"/> <input type="button" value="Delete All"/>														
	<table border="1"> <thead> <tr> <th>Mode</th> <th>Name</th> <th>Number</th> <th></th> </tr> </thead> <tbody> <tr> <td>1</td> <td><input type="text" value="Directory"/></td> <td><input type="text" value="voicemail"/></td> <td><input type="text" value="6750"/> <input type="button" value="Delete"/></td> </tr> <tr> <td>2</td> <td><input type="text" value="Directory"/></td> <td><input type="text" value="salvator"/></td> <td><input type="text" value="8021"/> <input type="button" value="Delete"/></td> </tr> </tbody> </table>	Mode	Name	Number		1	<input type="text" value="Directory"/>	<input type="text" value="voicemail"/>	<input type="text" value="6750"/> <input type="button" value="Delete"/>	2	<input type="text" value="Directory"/>	<input type="text" value="salvator"/>	<input type="text" value="8021"/> <input type="button" value="Delete"/>	<input type="button" value="New Contact"/> <input type="button" value="Delete All"/> <input type="button" value="Submit"/> <input type="button" value="Reset"/>	
Mode	Name	Number													
1	<input type="text" value="Directory"/>	<input type="text" value="voicemail"/>	<input type="text" value="6750"/> <input type="button" value="Delete"/>												
2	<input type="text" value="Directory"/>	<input type="text" value="salvator"/>	<input type="text" value="8021"/> <input type="button" value="Delete"/>												

1. New Contact: Add a new phonebook record.
2. Delete All: Delete all the phonebook records.
3. Mode: Directory or Blacklist. Numbers in Blacklist will be rejected when calling.
4. Name: name of a number, when the call of this number comes in the LCD will show the name.



5. Number: phone number.
6. Submit: Submit to apply the change.
7. Reset: Cancel the inputting.
8. Delete: Delete this record.

Notice: The maximum of records in the phone book is 200.

## 4.8 Call Log

Dialed	Received	Missed																				
	<p>Delete All</p> <table border="1"> <thead> <tr> <th></th> <th>Name</th> <th>Number</th> <th>Time</th> </tr> </thead> <tbody> <tr> <td>1:</td> <td>ATCOM User1</td> <td>0641</td> <td>27/11 17:37</td> </tr> <tr> <td>2:</td> <td>6750</td> <td>6750</td> <td>26/11 10:58</td> </tr> <tr> <td>3:</td> <td>6750</td> <td>6750</td> <td>26/11 10:52</td> </tr> </tbody> </table>		Name	Number	Time	1:	ATCOM User1	0641	27/11 17:37	2:	6750	6750	26/11 10:58	3:	6750	6750	26/11 10:52					
	Name	Number	Time																			
1:	ATCOM User1	0641	27/11 17:37																			
2:	6750	6750	26/11 10:58																			
3:	6750	6750	26/11 10:52																			
	<p>Delete All</p> <table border="1"> <thead> <tr> <th></th> <th>Name</th> <th>Number</th> <th>Time</th> </tr> </thead> <tbody> <tr> <td>1:</td> <td>HanYuHu</td> <td>8101</td> <td>10/02 17:40</td> </tr> <tr> <td>2:</td> <td>HanYuHu</td> <td>8101</td> <td>10/02 17:40</td> </tr> <tr> <td>3:</td> <td>ChenYuXing</td> <td>8115</td> <td>10/02 17:39</td> </tr> <tr> <td>4:</td> <td>ChenYuXing</td> <td>8115</td> <td>10/02 17:39</td> </tr> </tbody> </table>		Name	Number	Time	1:	HanYuHu	8101	10/02 17:40	2:	HanYuHu	8101	10/02 17:40	3:	ChenYuXing	8115	10/02 17:39	4:	ChenYuXing	8115	10/02 17:39	
	Name	Number	Time																			
1:	HanYuHu	8101	10/02 17:40																			
2:	HanYuHu	8101	10/02 17:40																			
3:	ChenYuXing	8115	10/02 17:39																			
4:	ChenYuXing	8115	10/02 17:39																			
	<p>Delete All</p> <table border="1"> <thead> <tr> <th></th> <th>Name</th> <th>Number</th> <th>Time</th> </tr> </thead> <tbody> <tr> <td>1:</td> <td>HanYuHu</td> <td>8101</td> <td>10/02 17:40</td> </tr> <tr> <td>2:</td> <td>ChenYuXing</td> <td>8115</td> <td>10/02 17:40</td> </tr> <tr> <td>3:</td> <td>ChenYuXing</td> <td>8115</td> <td>10/02 17:39</td> </tr> </tbody> </table>		Name	Number	Time	1:	HanYuHu	8101	10/02 17:40	2:	ChenYuXing	8115	10/02 17:40	3:	ChenYuXing	8115	10/02 17:39					
	Name	Number	Time																			
1:	HanYuHu	8101	10/02 17:40																			
2:	ChenYuXing	8115	10/02 17:40																			
3:	ChenYuXing	8115	10/02 17:39																			

1. Redial: Record of dialed list, maximum 200 records.
2. Received: Record of received list, maximum 200 records.
3. Missed: Record of Missed list, maximum 200 records.

## 5. FAQ & Trouble Shooting

### Frequently Asked Questions

#### 5.1 How to make a factory reset

There are three ways to make a factory reset:

1. Factory reset from keyboard, steps are:

- a) Press  and input password 123.
- b) Find and select '12 Factory Reset'.
- c) Press 'OK', then the phone will restart automatically and factory reset.

2. Factory reset through web, please refer to [Reset & Reboot](#);

3. Factory reset during rebooting, steps are:

- a) Keep pressing '\*' and '#' key.
- b) Plug in the power adapter.
- c) Wait for about 5 seconds and Rainbow2 will reset to factory after rebooted.

#### 5.2 Upgrade firmware under safe mode

If the phone could not start up normally, upgrade firmware under safe mode. Steps are:

1. Build a TFTP server and set its IP address as 192.168.1.200.
2. Copy the firmware to the root directory of the TFTP server and modify the file name as Rainbow2.FW.
3. Make sure the TFTP server and the phone are connecting with the same switch and reachable to each other;
4. Keep pressing '#' key and start up the phone until the LCD displays 'Upgrading...';
5. The phone will download the firmware from the TFTP server;
6. After the download is done, the phone will upgrade automatically;
7. After the update is finished, the phone will start up with the factory configuration.

#### 5.3 How to make direct IP call

When hook off/ pressing speaker or headset key,

1. Press soft key 'Num' until it switch to 'IP'.
2. Using '\*' key to input '.'. If user wants to dial 192.168.1.100, then press 192\*168\*1\*100.
3. After inputting the IP address, press dial key to dial it out.

## 6. Trouble Shooting

### 6.1 The phone can't register successfully

1. Check the IP address, and if the mode of WAN port is DHCP, please make sure the DHCP server is in service.
2. Check the gateway.
3. Check the DNS.
4. Make sure the information of the account is consistent with which offered by the service supplier.
5. Make sure the SIP server is on.
6. Check the port of the SIP server whose default value is 5060.

### 6.2 The phone can't obtain IP address

1. Make sure the cable has been connected to the LAN port of the phone.
2. Make sure the cable and the switch's port that connected with the cable is available.
3. Make sure the DHCP server is on and there are some assignable IP addresses in the address pool.
4. Try to change the LAN port mode as Static.

### 6.3 Only one part can hear the voice during the call

1. Make an IP dial-up call to make sure the telephone receiver and microphone are normal.
2. Enable STUN on web page.
3. Set STUN server as [stun.sipgate.com](http://stun.sipgate.com).
4. Click 'submit' and wait for the phone to restart.
5. Try to make calls again.

## 7. Abbreviations

DND : Do Not Disturb  
CFWD : Call Forward  
Bxfer : Blind Transfer  
Conf : Conference  
Num : Number  
DelChr : Delete Char  
Y/N : Yes/No  
SIP:Session Initiate Protocol  
RTP:Real-time Transport Protocol  
SDP:Session Description Protocol  
VPN:Virtual Private Network  
VLAN:Virtual Local Area Network  
QoS:Quality of Service  
Syslog : System log  
UDP:User Data Protocol  
TCP:Transmission Control Protocol  
TLS:Transport Layer Security Protocol  
BLF:Busy Lamp Field  
DNS:Domain Name System  
SRTP:Secure Real-time Transport Protocol  
NTP:Network Time Protocol  
VAD:Voice Activity Detection  
CNG:Comfort Noise Generator